

Design-for-Manufacturability (DFM) Tips for Miniature Biomedical Sensor Circuits



Introduction

Advanced foundry processes have enabled a new age of sensor circuit engineering, and designers in many fields from RF communications, embedded vision systems, and medical devices, are actively exploring new ways to employ them. One such foundry process, micron-level thin film technology, is becoming especially intriguing to designers of biomedical sensors. Thin-film circuits can be applied to flexible polyimide substrates making them capable of being bent and shaped considerably without impact on circuit performance or reliability. As such, the combination of flexible material and thin-film circuit geometries is leading medical designers to consider how far they can go in an attempt to enhance their sensors for advanced procedures, and improved patient care.

TECHNICAL BRIEF

DESIGN-FOR-MANUFACTURABILITY (DFM) TIPS FOR MINIATURE BIOMEDICAL SENSOR CIRCUITS

For medical designers pivoting from one scale to another, however, there is often an immediate challenge of resolving their engineering ideas using dramatically less real estate. Many come from companies whose devices have been traditionally limited by the line and spacing constraints of single layer thick-film or traditional flex circuit design on Kapton (which typically stops at around 2 mils). Considering that micron-scale thin film allows for a reduction in lines and spaces by over 100%, and also allows for multilayer techniques, a certain amount of education is required for designs to be production-ready.

This Tech Brief aims to outline the top 7 considerations biosensor circuit designers should pay close attention to early in the earliest stages of prototype development.

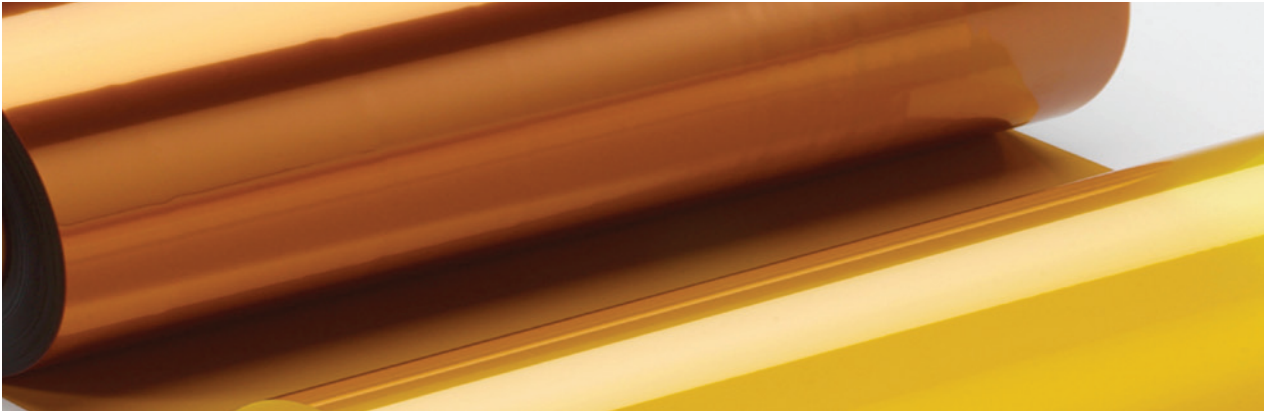

Further Understanding the Circuit Design Challenge

Though a medical device designer may be an expert in the specific application and sensing technology employed in a device, this expertise does not necessarily translate to building that technology on a large scale with stringent reliability constraints. Moreover, because the variables and potential combinations are difficult to define, so to are standard design guidelines.

Conventional flex circuits use rolls of Kapton, a Dupont™ polyimide film pre-clad with metal, and are bonded with adhesives between

each layer. This process keeps layer thickness stuck at around 1-5 mils. Thin-film flex circuits rely on custom spun polyimide polymer films on glass, and this approach enables miniature flex circuits up to six layers, with layer thicknesses as thin as 10 microns or less. Trace lines and spaces for this technology can be as small as ten microns, and via hole diameters can be as low as 15 microns, or .00059 mil. The significant increase in circuit density and proximity of circuit traces and features, naturally leads to electrical and mechanical considerations more akin to integrated circuits (ICs) than prior flex circuit technologies.

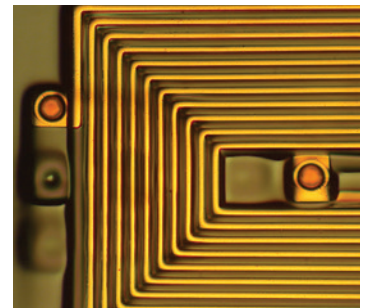

TECHNICAL BRIEF

DESIGN-FOR-MANUFACTURABILITY (DFM) TIPS FOR MINIATURE BIOMEDICAL SENSOR CIRCUITS

1. Become a Maestro of Micro-circuit Traces, Spaces, Vias, and Crossovers.

Like a conductor moving from a symphony to a quartet, circuit designers moving dramatically down in scale from millimeters to microns, while still having to create the same kind of performance, need to become resourceful and creative. But with limited time and capability for numerous trials and errors, it's important to enter into prototyping with new knowledge. What's also important to recognize is that the typical practice of exaggerating circuit features to simplify characterization, is exponentially compounded due to the difference in scale. While making test points large and accessible often allows for simplified early stage evaluation, it can be a pitfall to count on the features around them ever being anything near their position or size at a submicron level.

As you'll see, when DFM is considered for micron level designs, the circuit design will likely undergo many changes in feature size and positioning for optimization. This includes defining key relationships, such as line width to metal thickness ratios, stitching vias to a pad width, stackup, and insulation/thermal layer thicknesses, among other variables.

Among the most critical constraints to be aware of, are the via to pad size ratios. The minimum ratio for this depends on many factors, including insulation and metal thicknesses, which can be different for every

design. A related constraint is the spacing between vias, and pads. For extremely dense interconnects, the capacitive and inductive parasitics are more of a concern, as these parameters have a greater impact on closely spaced leads, pads, and vias.

Both capacitive coupling and inductive coupling are a function of distance. For very sensitive biomedical sensor circuits, noise and interference can be coupled in from close adjacent conductors. With extremely narrow and complex routing sensor leads, it is often challenging to avoid these parasitics, and it is advisable to consider their impact early in the design phase. Many traditional rule-of-thumb approximations for parasitics may not apply at miniaturized geometries, and more detailed and exact simulations may be required to more closely approximate real-world performance.

Interconnect between the thin-film materials and components, as well as biosensor leads, is another area for critical consideration. There are standard thin-film attach methods, also used throughout the microelectronics industry, such as wire bond, solder, and epoxy attach. However, certain requirements, such as higher conductivity and greater bond strength, may require selectively plating the pads to enable attach methods that meet specific criteria.

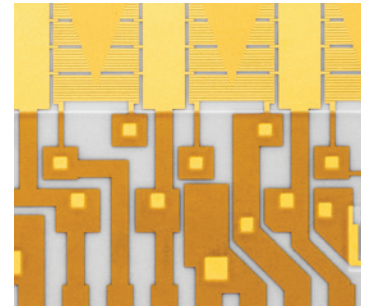

“For extremely dense interconnects, the capacitive and inductive parasitics are more of a concern, as these parameters have a greater impact on closely spaced leads, pads, and vias.”

TECHNICAL BRIEF

DESIGN-FOR-MANUFACTURABILITY (DFM) TIPS FOR MINIATURE BIOMEDICAL SENSOR CIRCUITS

2. Understand the Potential Ramifications of Substrate Material and Metallization Choices.

There are many DFM considerations surrounding your choice in substrates and layering techniques. The first two critical choices are choosing a substrate type and thickness. The type and thickness of a substrate impacts the physical, thermal, and electrical properties of the final micro-circuit. The third choice is choosing the material makeup of the various circuit traces and layering material. In addition to various performance and repeatability variables, there may also be limitations of what metals and other compounds can be used in certain medical sensor applications, especially those used in-body. Moreover, the circuits on each layer will intrinsically interact with each other, making finite circuit layout as critical as functional electrical design. Improperly selected materials and geometries, and non-compatible circuit layouts are the most common causes of circuit rejection at the production stage. But what can be even more costly are circuits that go undetected as problematic until prototypes are run and tested and/or passed along to a customer for review and then fails under use conditions.

Typically, the metal thickness of a thin-film circuit correlates directly with the size of the circuit lead and pad features. Furthermore, the substrate, or insulation layer, is related to the metal thickness, as the substrate must completely cover the underlying metal. Hence, the most critical circuit feature geometry will likely decide the thickness of the metal and substrate for that particular layer, though thicknesses may vary from layer to layer, unlike many PCB processes. There is a

limit to the minimum metal and substrate layer thicknesses, and this is what determines the minimum circuit feature size.

With the complex geometries of biomedical sensor circuits, grounding, shielding, and trace characteristics may require deeper consideration than larger scale processes. This is a product of a conductors grounding and shielding effectiveness being a function of sheet resistance of a material at the frequency and power of the intended and unintended signals conducted. The same goes for traces, which makes deciding on a metal feature's size and thickness very important.

3. Don't Forget the Final Installation and Usage Dynamics

The number of layers, layer thickness, and circuit features all factor into the size, shape, and flexibility of a miniature and flexible thin film circuit. Depending on the end application, such as surgical implantation by hand, or integration into an automated manufacturing process, the physical dynamics of the circuit may also be important factors to consider.

The overall circuit flatness, temporary adhesion strength to a carrier, and final release strength may be dynamics that could be missed among the other details of biosensor circuit design. These are additional factors could impact the yield, reliability, ease of installation, and other important aspects of end-use. Unlike standard flex circuits, microminiature flex circuits are not designed to be constantly exercised, and installation in a motion application may result in circuit degradation and failure.

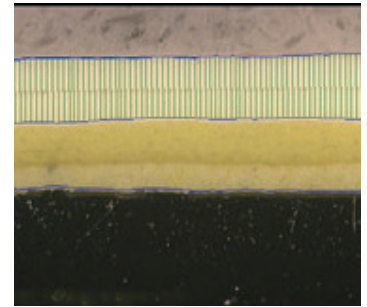

Thickness Measurement

Depending on the materials used and the desired circuitry properties, thin-film metal and insulator layer thicknesses must be kept within a certain ratio for reliable processing.

TECHNICAL BRIEF

DESIGN-FOR-MANUFACTURABILITY (DFM) TIPS FOR MINIATURE BIOMEDICAL SENSOR CIRCUITS

4. What About Special Features?

If certain special features used to enhance the competitiveness of your biosensor or medical device over other products is required it's important these be on the table early with your manufacturing partner. This could be anything from bonding bumps, use of exotic metals, micro-circuit stiffeners, and extremely dense circuit patterns. All of which, need to be considered during the design stage to avoid unfortunate redesign and revalidation.

Exotic materials may incur substantially greater costs that will price them out of the market, and there may be a limit to how, or if, they can be processed. Some metals are unable to be processed in the presence of others, as certain metals and processing agents may interact chemically. For example, platinum can only be used on a gold circuit if it's added to the metal stack during the optimal process step. This is a result of the platinum metal etchant also etching all other metal types. This is somewhat similar to a solder hierarchy used in PCB and PCBA manufacturing.

5. Avoid the Pitfall of Assuming That if it Works in the Graduate Lab it Will Work at Volume.

It's common practice for many medical device companies to collaborate with advanced scientific and engineering Universities to develop next-generation technologies and devices. But, a common pitfall of this practice is that there's a presumption that the prototype manufacturing tools and equipment used in a University lab—that

may have led to working models and small volumes of a circuit—are the same as those required to produce a circuit at high volume. (This is not limited to University research. Expert medical designers at major brands often make similar errors in their own labs). Teaming up with a thin-film manufacturing partner early in the design phase can help to prevent development going down a road that later requires redesign when approaching manufacturing at volume.

6. Don't Overspecify to the Point of Overkill.

It may be hard to imagine that a medical device may be specified to be "too good". But as any engineering team knows, it's not a designer's nature to leave anything on the table in regards to performance. Overspecification occurs when a particular performance parameter is overvalued, or there isn't a precise understanding of a nominal range for a parameter. This can lead to redesign, material swaps, and manufacturing trials that will increase costs and time-to-market. Ensuring that nominal parameters, and involving a manufacturing partner early in the design process, can help prevent over-specification and improve the competitive position of your biosensor or medical device in the market.

7. Properly Prepare your CAD Files.

Though struggling through the minutia of correcting every design rules check (DRC) and layout versus schematic (LVS) error may be painful, it is necessary before handing off a design to a manufacturing partner. As the manufacturer may use different software



Design Compromises Don't Always Equal Device Compromises

Medical sensor circuit designers are as susceptible to over-engineering as anyone. Taking a team approach to design is the best way to weigh trade-offs relative to time-to-market and the true value of a design feature.

TECHNICAL BRIEF

DESIGN-FOR-MANUFACTURABILITY (DFM) TIPS FOR MINIATURE BIOMEDICAL SENSOR CIRCUITS

tools to interpret the CAD files, any unaddressable errors could be compounded when being prepared by the manufacturer. Another reason, is that there could be nested errors that only reveal themselves after a particular DRC or LVS error has been corrected. Without correcting these errors, unintended circuit performance is possible, and tracking down and correcting these issues could delay time-to-market.

It is often more efficient to follow a systematic design process that minimizes errors, than having to backtrack each time an error is encountered, especially if correcting one error creates another.

During a CAD file review, your thin film manufacturing partner will analyze every individual line and feature to ensure that is properly drawn. Ideally, a customer supplied email of the DWG or DXF file with accompanying properly dimensioned PDF drawing of the final product can help to ensure the efficiency of this process. The following are common errors that circuit designers often make:

- Overlapping and/or incomplete lines
- Inaccurate or missing labels of all layers
- Missing features
- CAD drawings that don't exactly match the specification drawing
- Revision control related issues

Conclusion

Industry disrupting breakthroughs using more compact and flexible micro-circuits in biomedical sensors and other devices are enabling innovative medical sensing solutions with much greater performance, capabilities, and accuracy than ever before. However, these miniature, micron-scale electronics often require another level of circuit design expertise, especially as compared to traditional flex circuit or PCB design. This is especially the case when designing thin film circuits for manufacturability in medium to high volumes. In addition to all of the considerations mentioned above, the application engineering and DFM expertise of your thin film manufacturing partner can also be a make or break decision when pioneering new devices in this highly competitive market.



Next Steps:

[Download our thin film circuit design guidelines](#)

[Learn more from our insightful blogs](#)

[Read our FAQs and Submit a DFM support question](#)

[Request a Quote](#)